

TOSHIBA BiCD Integrated Circuit Silicon Monolithic

TB6674PG, TB6674FG, TB6674FAG

Stepping Motor Driver IC

TB6674PG, TB6674FG, and TB6674FAG are stepping motor driver ICs with MOS output transistors.

The ICs can control two-phase stepping motor forward and reverse by bipolar driving. They have a power-saving circuit and a standby circuit.

Features

- They are similar substituting products of TA7774PG, TA7774FG, and TA7774FAG. Both products have same packages and same pin assignments.
- One-chip two-phase bipolar stepping motor driver (including two bridge drivers)
- Power saving operation is available.
- Standby operation is available.
Current consumption $\leq 20 \mu\text{A}$ (typ.)
- Built-in punch-through current restriction circuit for system reliability and noise suppression.
- TTL-compatible inputs INA, INB, PS, and Vs2B terminals
- ON resistance PS = L : 2.9Ω (Typ.)
PS = H: 7.9Ω (Typ.)
- High driving ability.
<TB6674PG/FG>
: IO (START) 350 mA (MAX.) : VS1 ENABLE
: IO (HOLD) 100 mA (MAX.) : VS2 ENABLE
<TB6674FAG>
: IO (START) 100 mA (MAX.) : VS1 ENABLE
: IO (HOLD) 50 mA (MAX.) : VS2 ENABLE
- Typical PKG DIP16 pin, HSOP16 pin, SSOP16 pin
- GND terminal = HEAT SINK
- Process :BiCD0.6 (30 V)
- Over current shutdown circuit (ISD).
- Thermal shutdown circuit (TSD).
- Undervoltage lockout circuit (UVLO).
- Pull-down resistance for input terminal ($250 \text{ k}\Omega$).

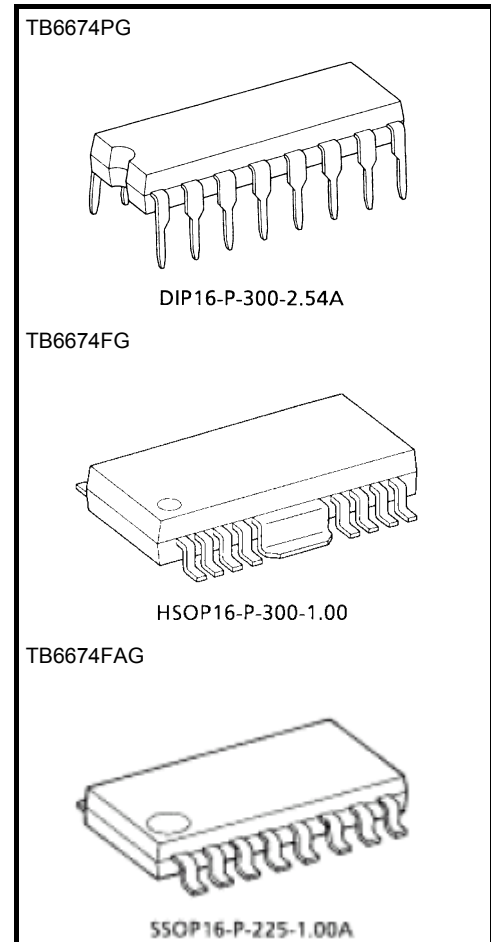

Weight

DIP16-P-300-2.54A: 1.11 g (typ.)
HSOP16-P-300-1.00: 0.50 g (typ.)
SSOP16-P-225-1.00A: 0.14 g (typ.)

The following conditions apply to solderability:

About solderability, following conditions were confirmed

(1)Use of Sn-37Pb solder Bath
·solder bath temperature: 230°C
·dipping time: 5 seconds
·the number of times: once
·use of R-Type flux

(2)Use of Sn-3.0Ag-0.5Cu solder Bath
·solder bath temperature: 245°C
·dipping time: 5 seconds
·the number of times: once
·use of R-type flux

Block Diagram

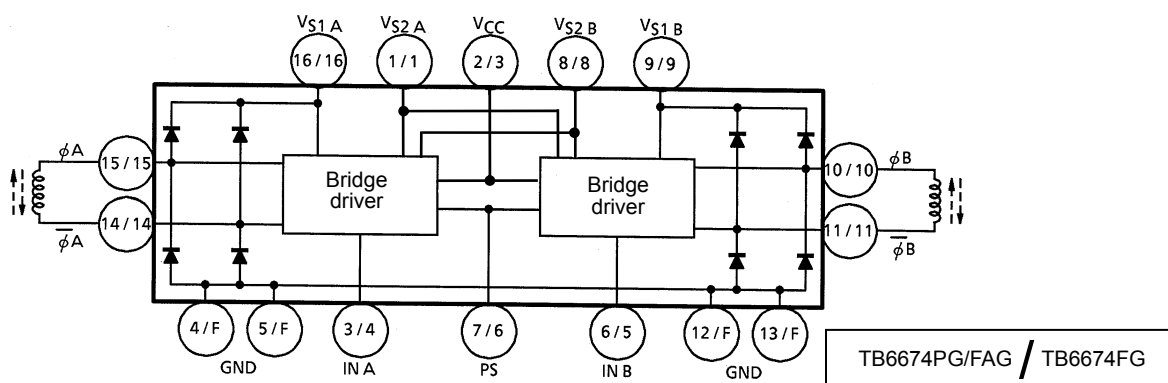

Note: TB6674FG: Terminals 2, 7, 12, and 13 are NC.

TB6674FG: The heat fin is connected to GND.

Pin Description

Pin No.	Symbol	Functional Description
1 / (1)	VS2 A	Low-voltage power supply terminal
2 / (3)	VCC	Power voltage supply terminal for control
3 / (4)	IN A	A-ch forward rotation / reverse rotation signal input terminal, Truth Table 1
4 / (F)	GND	GND terminal
5 / (F)	GND	GND terminal
6 / (5)	IN B	B-ch forward rotation / reverse rotation signal input terminal, Truth Table 1
7 / (6)	PS	Power saving signal input terminal
8 / (8)	VS2 B	Standby signal input terminal, Truth Table 2
9 / (9)	VS1 B	High-voltage power supply terminal
10 / (10)	φB	Output B
11 / (11)	φ̄ B	Output \bar{B}
12 / (F)	GND	GND terminal
13 / (F)	GND	GND terminal
14 / (14)	φ̄ A	Output \bar{A}
15 / (15)	φA	Output A
16 / (16)	VS1 A	High-voltage power supply terminal.

Pin No. of () :TB6674FG

Truth Table 1.

Input		Output		
PS	IN	φ	$\bar{\Phi}$	
L	L	L	H	ENABLE V_{S1}
L	H	H	L	ENABLE V_{S1}
H	L	L	H	ENABLE V_{S2} (Power saving)
H	H	H	L	ENABLE V_{S2} (Power saving)

Truth Table 2.

V_{S2B}	
L	POWER OFF (Standby mode)
H	OPERATION

Note: Apply 5 V to V_{S2A} as a supply terminal.

<Terminal circuit>

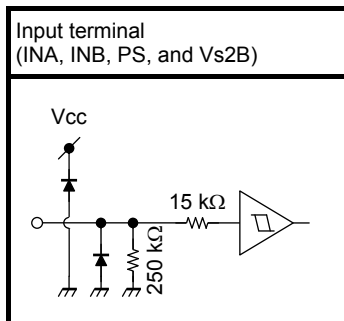

The diagram is partly-provided and omitted or simplified for explanatory purposes.

Absolute Maximum Ratings (Ta = 25°C)

Characteristic		Symbol	Rating	Unit
Supply voltage		V _{CC}	6.0	V
		V _{S1}	24.0	
		V _{S2}	Up to V _{CC}	
Output current	TB6674PG TB6674FG	I _O (PEAK)	±400	mA
		I _O (START)	±350	
		I _O (HOLD)	±100	
	TB6674FAG	I _O (PEAK)	±200	
		I _O (START)	±100	
		I _O (HOLD)	±50	
Input voltage		V _{IN}	Up to V _{CC}	V
Power dissipation	TB6674PG	P _D	1.4 (Note 1)	W
			2.7 (Note 2)	
	TB6674FG		0.9 (Note 3)	
			1.4 (Note 4)	
	TB6674FAG		0.78 (Note 5)	
Operating temperature		T _{opr}	−30 to 75	°C
Storage temperature		T _{stg}	−55 to 150	°C

Note 1: IC only

Note 2: This value is obtained if mounting is on a 50 mm × 50 mm × 0.8 mm PCB, 60 % or more of which is occupied by copper.

Note 3: IC only

Note 4: This value is obtained if mounting is on a 60 mm × 30 mm × 1.6 mm PCB, 50 % or more of which is occupied by copper.

Note 5: This value is obtained if mounting is on a 50 mm × 50 mm × 1.6 mm PCB, 40 % or more of which is occupied by copper.

Operating Conditions (Ta = 25°C)

Characteristic		Symbol	Min.	Typ.	Max.	Unit
Supply voltage		V _{CC}	4.5	—	5.5	V
		V _{S1}	8.0	—	22.0	
		V _{S2A}	2.7	—	5.5	
Output current	TB6674PG TB6674FG	I _O	—	—	±350	mA
	TB6674FAG	I _O	—	—	±100	
Input voltage		V _{IN}	0	—	V _{CC}	V
Maximum frequency of input pulse		f _{IN}	—	—	25	kHz
Minimum resolution of input pulse		t _w	20	—	—	μs

Value of ON resistance tends to increase when the difference between Vs1 and Vs2A becomes 5 V or less.

Electrical Characteristics (Unless otherwise specified, Ta = 25°C, Vcc = 5 V, Vs1 = 12 V, and Vs2A = 5 V)

Characteristic		Symbol	Test Circuit	Test Condition	Min	Typ.	Max	Unit	
Supply current		I _{CC1}	1	PS: H, V _{S2B} : H	—	3	5	mA	
		I _{CC2}		PS: L, V _{S2B} : H	—	3	5		
		I _{CC3}		V _{S2B} : L	—	1	20	μA	
Input voltage	High	V _{INH}	—	INA, INB, PS, Vs2B	2.0	—	V _{CC}	V	
	Low	V _{INL}			−0.2	—	0.8		
Input hysteresis voltage*		V _{INhys}			1		—	90	—
Input current		I _{IN (H)}	1	INA, INB, PS, Vs2B V _{IN} = 5.0 V Built in pull-down resistance.	5	20	38	μA	
		I _{IN (L)}		V _{IN} = 0 V	—	—	1	μA	
Output ON resistance (Note)	TB6674PG TB6674FG	R _{on 1H}	2	PS: L, V _{S2B} : H	I _{OUT} = 400 mA	—	2	5	Ω
		R _{on 2H}	3	PS: H, V _{S2B} : H	I _{OUT} = 100 mA	—	7	16	
		R _{on L}	2	V _{S2B} : H	I _{OUT} = 400 mA	—	0.9	3.5	
	TB6674FAG	R _{on 1H}	2	PS: L, V _{S2B} : H	I _{OUT} = 200 mA	—	2	5	
		R _{on 2H}	3	PS: H, V _{S2B} : H	I _{OUT} = 50 mA	—	7	16	
		R _{on L}	2	V _{S2B} : H	I _{OUT} = 200 mA	—	0.9	3.5	
Diode forward voltage		V _{F U}	4	I _F = 350 mA, PS = L	—	1.2	2.5	V	
		V _{F L}			—	1.0	2.2		
Delay time		t _{pLH}	—	IN - φ	—	0.5	—	μs	
		t _{pHL}			—	0.5	—		
Thermal shutdown circuit*		TSD	—	(Design target only)	—	160	—	°C	
TSD hysteresis *		TSDhys	—	(Design target only)	—	20	—	°C	

* : Toshiba does not implement testing before shipping.

Undervoltage Lockout Circuit (UVLO)

The TB6674 incorporates an under voltage lockout circuit.

Outputs are turned off (Hi-Z) under the conditions as follows:

$V_{CC} \leq 4.0\text{ V}$ (Design target) or

$V_{S1A} \leq 6.0\text{ V}$ (Design target) and $V_{S1B} \leq 6.0\text{ V}$ (Design target) or

$V_{S2A} \leq 2.2\text{ V}$ (Design target)

The UVLO circuit has a hysteresis and the function recovers under the conditions as follows:

$V_{CC} = 4.1\text{ V}$ (Design target), $V_{S1A}/V_{S1B} = 6.5\text{ V}$ (Design target), $V_{S2A} = 2.3\text{ V}$ (Design target)

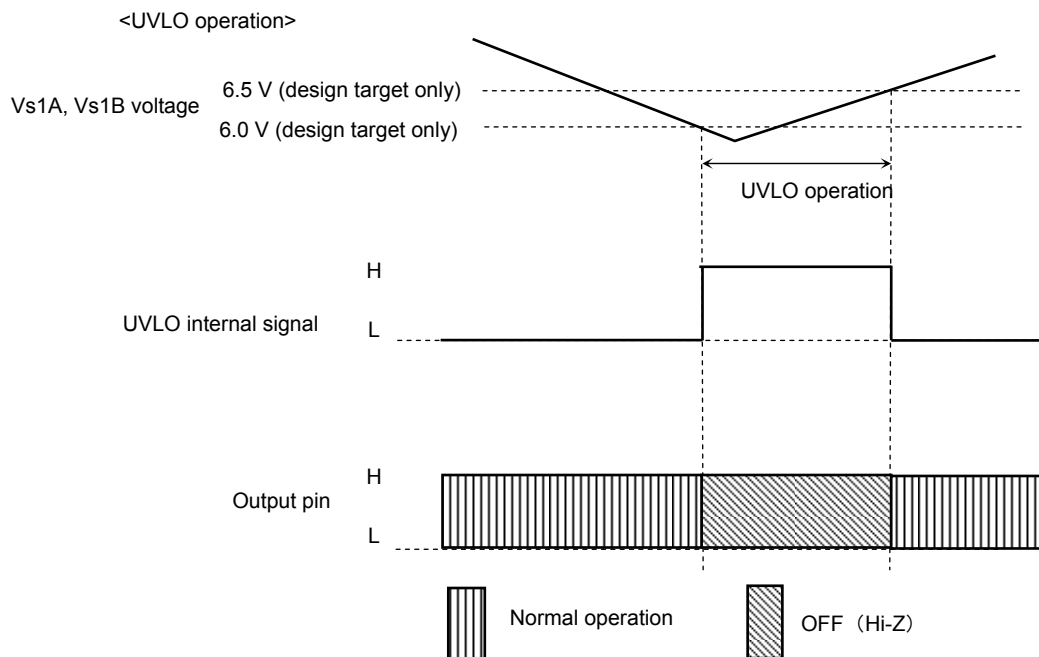
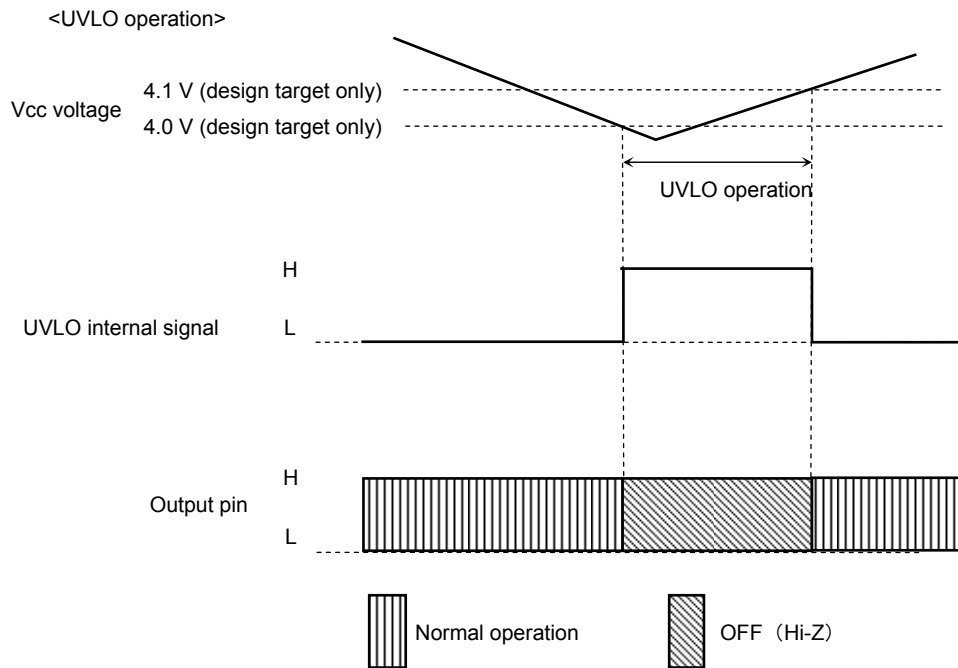

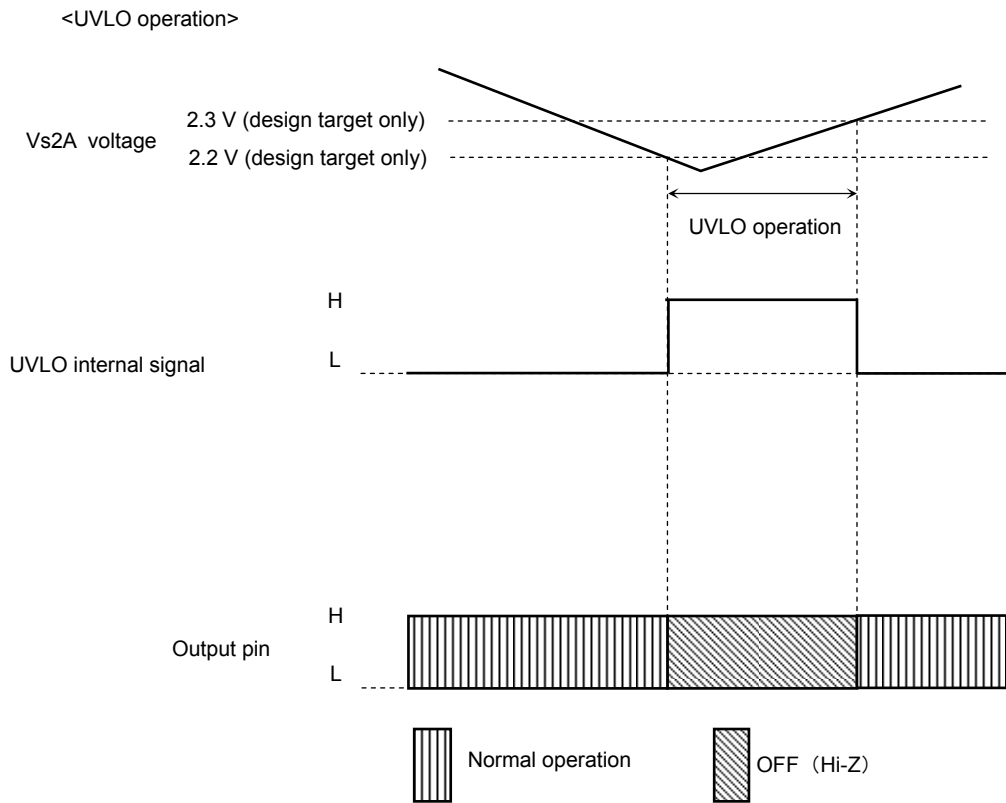

Over Current Protection (ISD) Circuit

The IC incorporates the over current protection circuit that monitors the current flowing through each output power transistor. If a current, which is out of the detecting current, is sensed at any one of these transistors, all output transistors are turned off (Hi-Z). (However, ISD is not incorporated in upper PchDMOS when PS is high level (Vs2A is 5 V usage) because ON resistance is large.

Masking time is 20 μ s. The operation does not recover automatically (latch method). There are two recovery methods written below.

- (1) Power monitor turns on when any of the power supply decreases and reaches the specified voltage.
- (2) Vs2B is set low level for 20 μ s or more and then set high. The operation recovers in 10 μ s.

Reference design target of detecting current is as follows;

PS = L, VS1A (12 V) :PchDMOS = 1.1 A

PS = H/PS = L in common :Lower NchDMOS = 1.4 A

Please reduce the external noise to prevent malfunction for ISD.

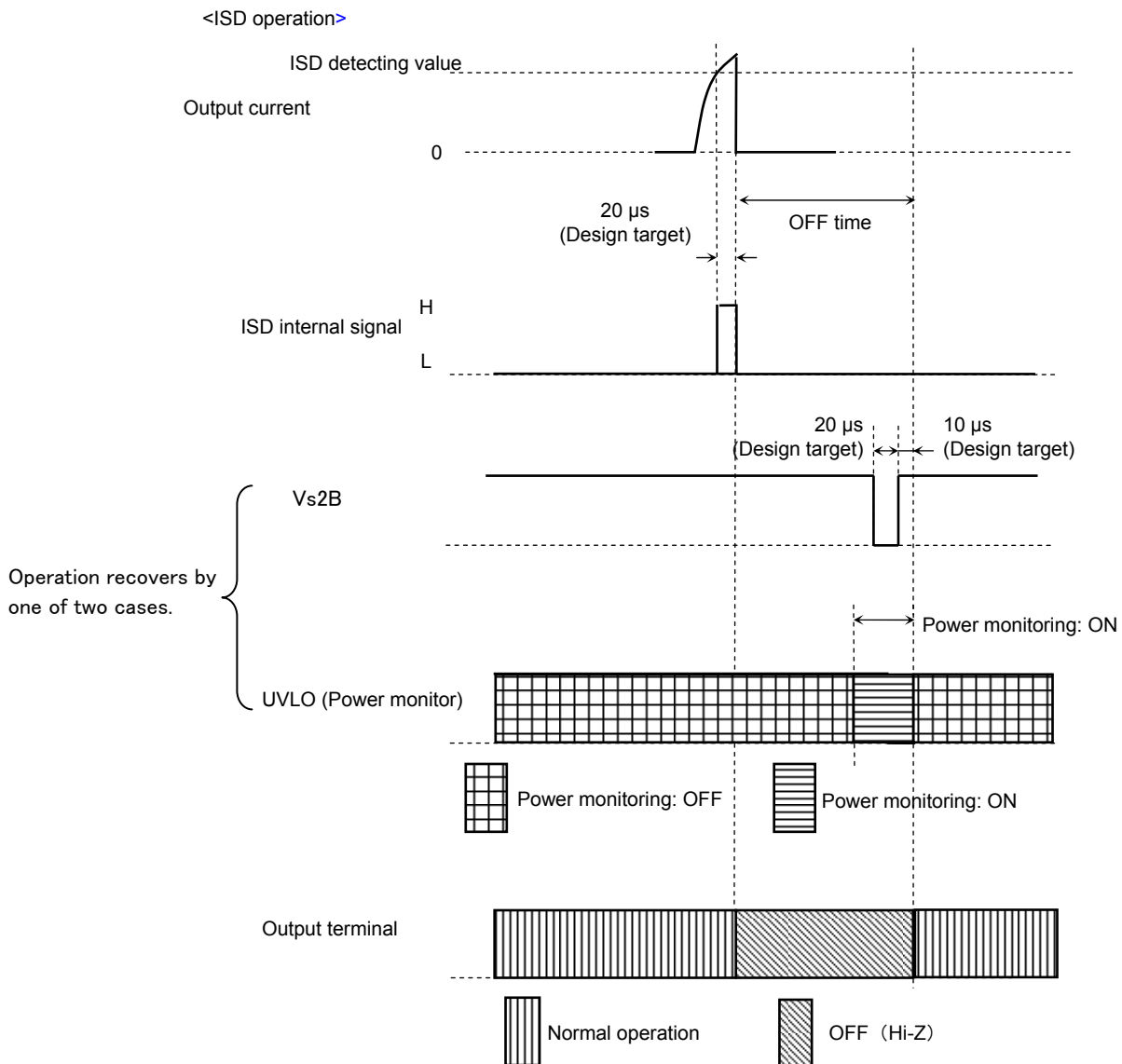

Thermal Shutdown Circuit (TSD)

The TB6674 incorporates a thermal shutdown circuit. If the junction temperature (T_j) exceeds 160°C (design target only), all the outputs are turned off (Hi-Z). It recovers automatically at 140°C. It has a hysteresis width of 20°C.

TSD = 160°C (design target only)

< TSD operation >

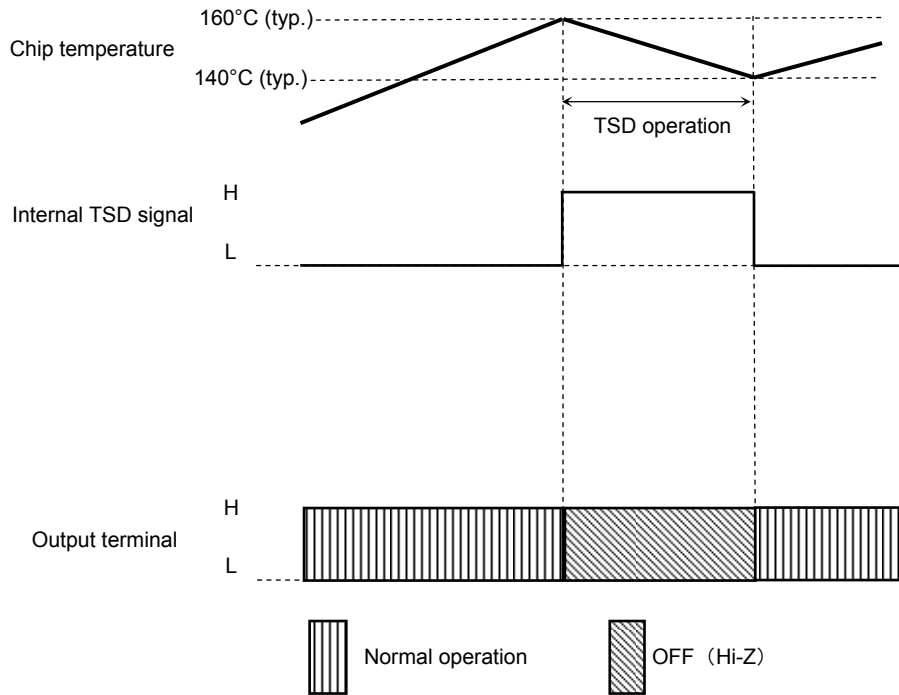

Test Circuit 1. I_{CC1} , I_{CC2} , I_{CC3} , $I_{IN A}$, $I_{IN B}$, and I_{PS}

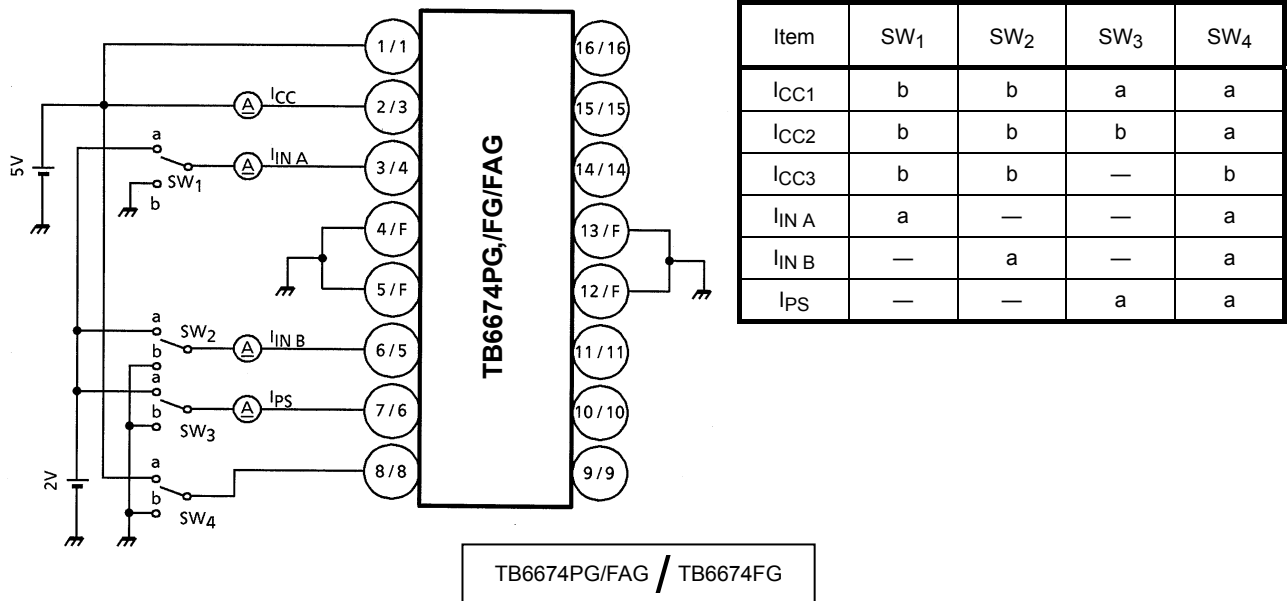

All terminals of INA, INB, and PS should output low or be connected to the ground terminal in measuring I_{CC3} .

Test Circuit 2. Ron 1H1, Ron 1H2, Ron L2, and Ron L3

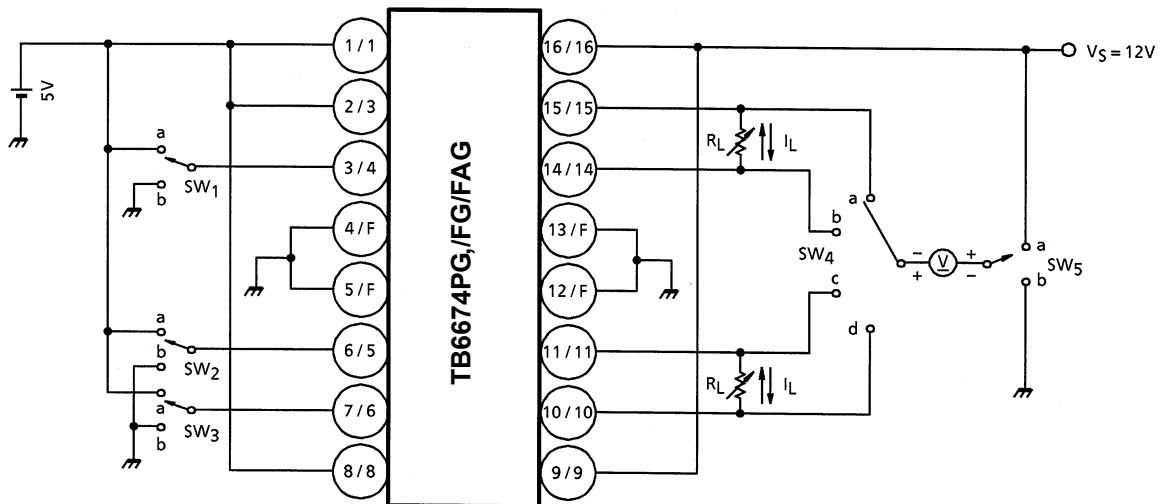

*: Adjust R_L to correspond to I_L .

Item	SW ₁	SW ₂	SW ₃	SW ₄	SW ₅	I_L (mA)
V _{SAT} 1H1	a	—	b	a	a	100
	b	—		b		
	—	a		d		
	—	b		c		
V _{SAT} 1H2	a	—	b	a	a	400
	b	—		b		
	—	a		d		
	—	b		c		
V _{SAT} L2	a	—	—	b	b	100
	b	—		a		
	—	a		c		
	—	b		d		
V _{SAT} L3	a	—	b	b	b	400
	b	—		a		
	—	a		c		
	—	b		d		

Test Circuit 3. Ron 2H1, Ron 2H2, and Ron L1

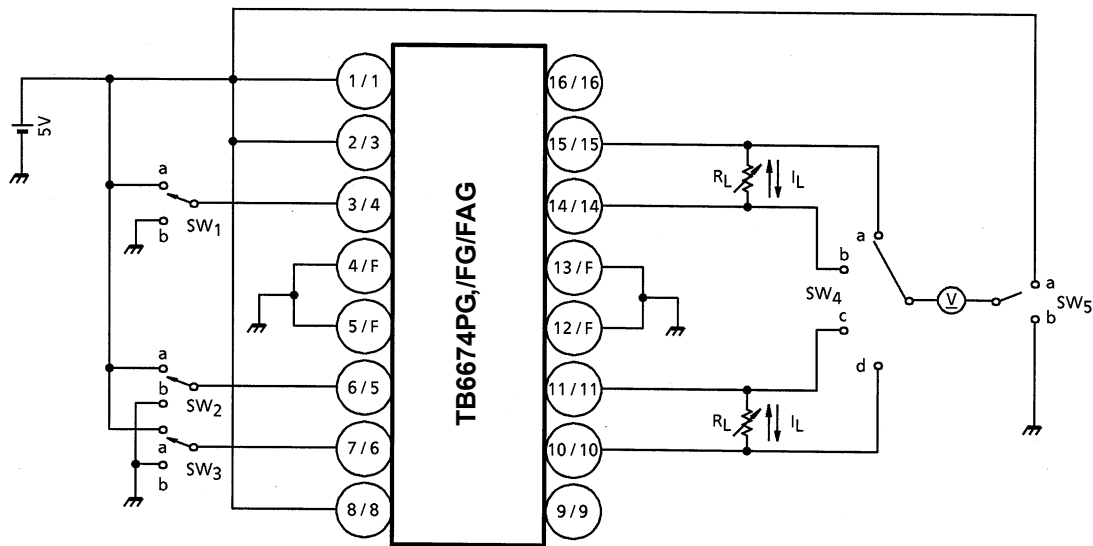

*: Adjust R_L to correspond to I_L .

Item	SW ₁	SW ₂	SW ₃	SW ₄	SW ₅	I_L (mA)
V _{SAT} 2H1	a	—	a	a	a	20
	b	—		b		
	—	a		c		
	—	b		d		
V _{SAT} 2H2	a	—	a	a	a	100
	b	—		b		
	—	a		c		
	—	b		d		
V _{SAT} L1	a	—	a	b	b	20
	b	—		a		
	—	a		c		
	—	b		d		

Test Circuit 4. V_{FU} and V_{FL}

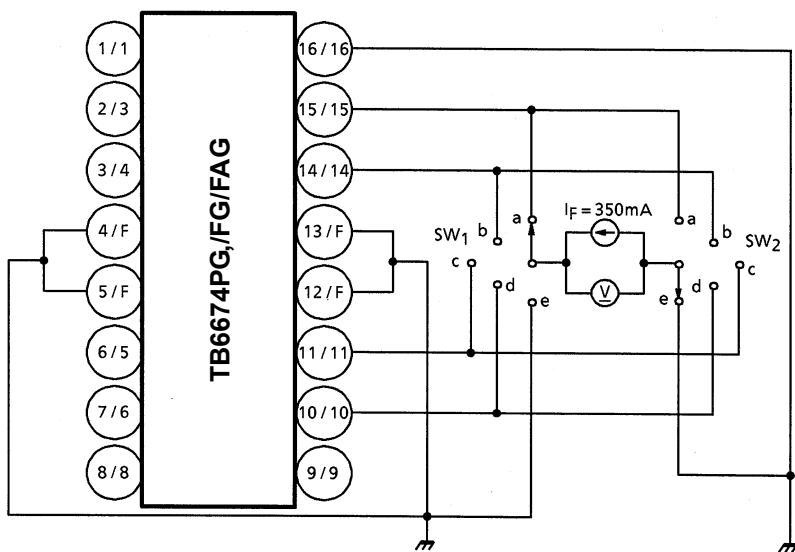

Measuring Method

Item	SW ₁	SW ₂
V_{FU}	a	e
	b	
	c	
	d	
V_{FL}	e	a
		b
		c
		d

Timing Chart (two-phase excitation)

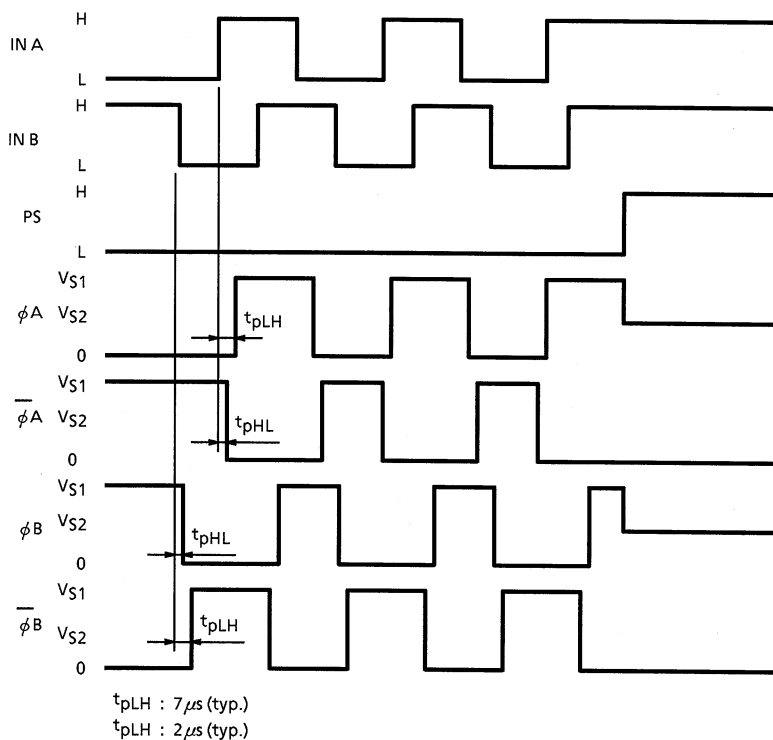

Thermal Performance Characteristics

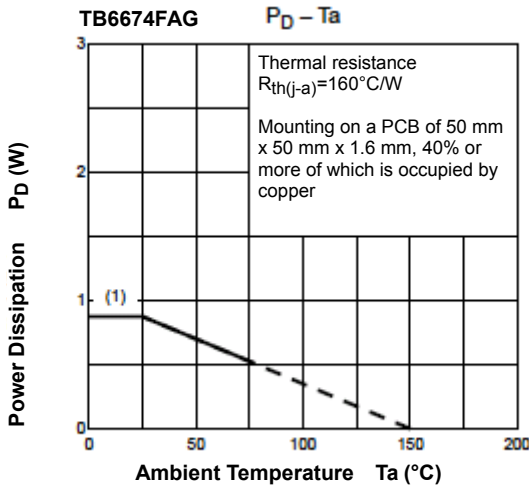
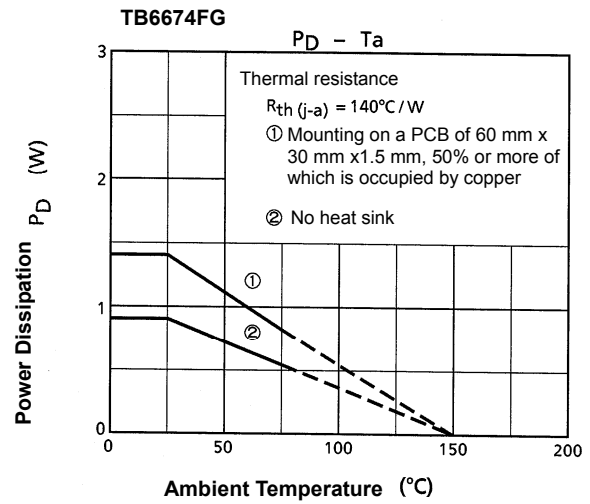
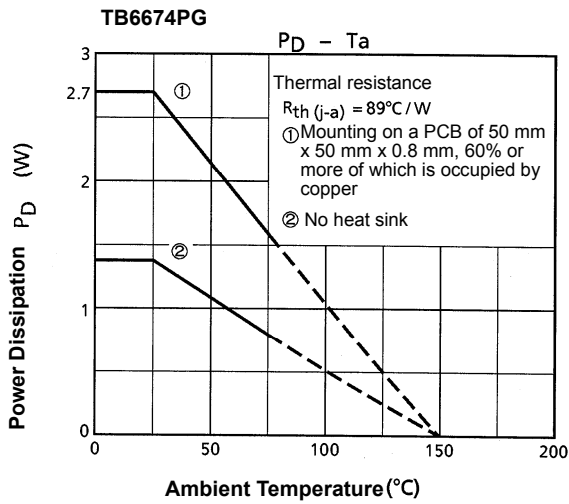

Application Circuit

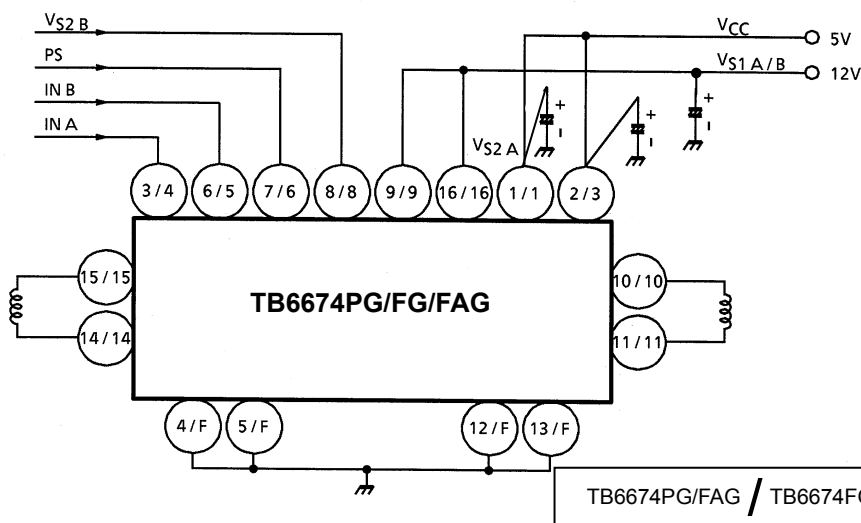

Note 1: Connect the V_{S2A} terminal to the lower supply voltage (5 V).

Note 2: Supply smoothing capacitor* should be connected between each supply terminal (V_{CC} , V_{S2A} , and $V_{S1A/B}$) and GND terminal. *: (Ex.): Capacitors of tens of μF and $0.1 \mu\text{F}$ which are connected in parallel.

Note 3: Utmost care is necessary in the design of the output, V_{CC} , V_M , and GND lines since the IC may be destroyed

by short-circuiting between outputs, air contamination faults, or faults due to improper grounding, or by short-circuiting between contiguous terminals.

Note 4: By our short-circuited examination of neighboring terminals, when 9 and 10 terminals or 15 and 16 terminals are short-circuited, the TB6674PG, TB6674FG, and TB6674FAG in any case might to be destroyed and cause the trouble of smoking etc. Please use an appropriate fuse to the power supply line.

Note 5: Connect V_{S1A} terminal and V_{S1B} terminal externally.

Note 6: Connect each GND terminal externally.

Package Dimensions

DIP16-P-300-2.54A

Unit: mm

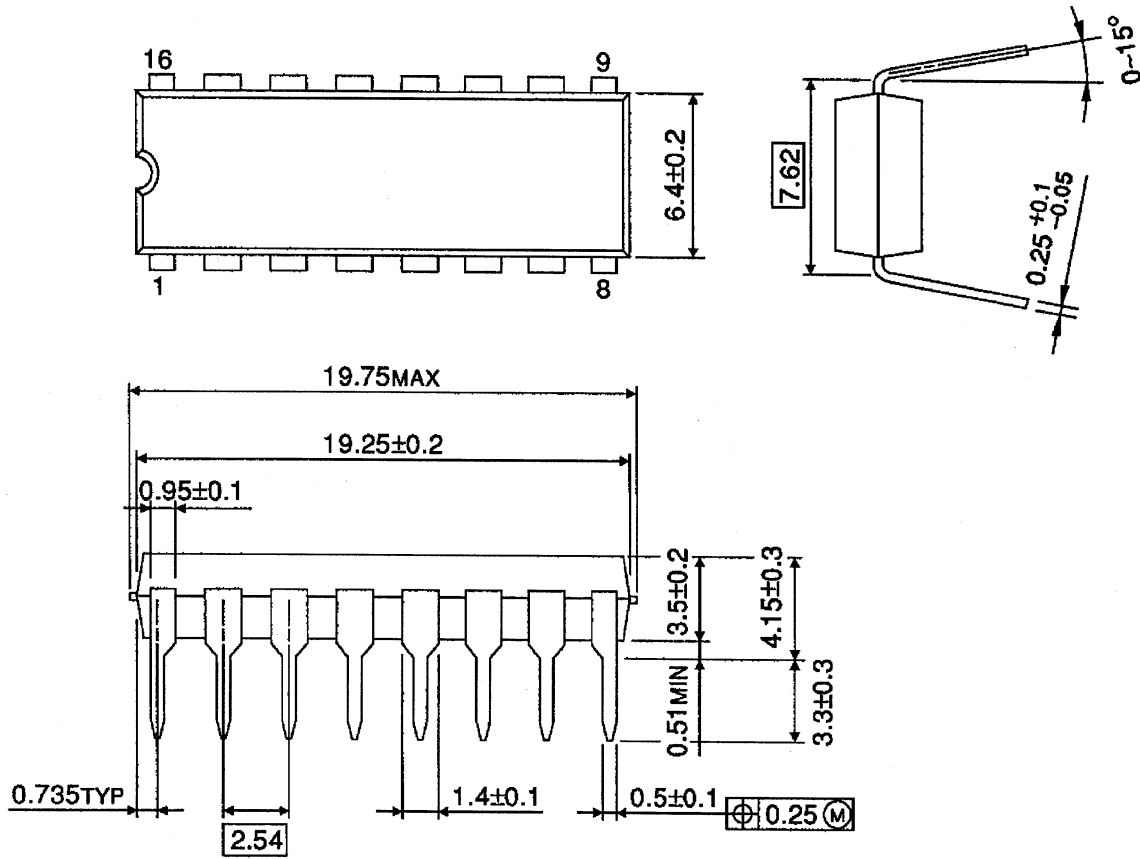

Weight: 1.11 g (Typ.)

Package Dimensions

HSOP16-P-300-1.00

Unit: mm

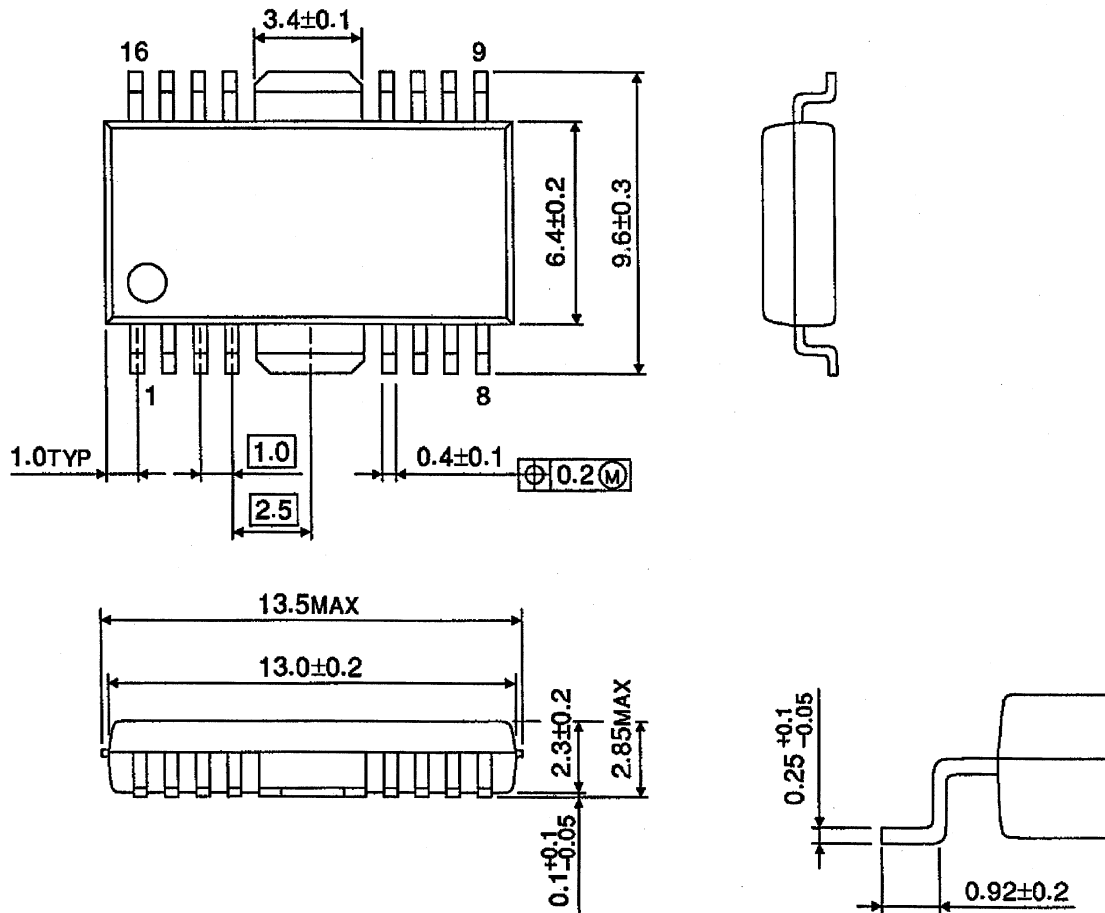

Weight: 0.50 g (Typ.)

Package Dimensions

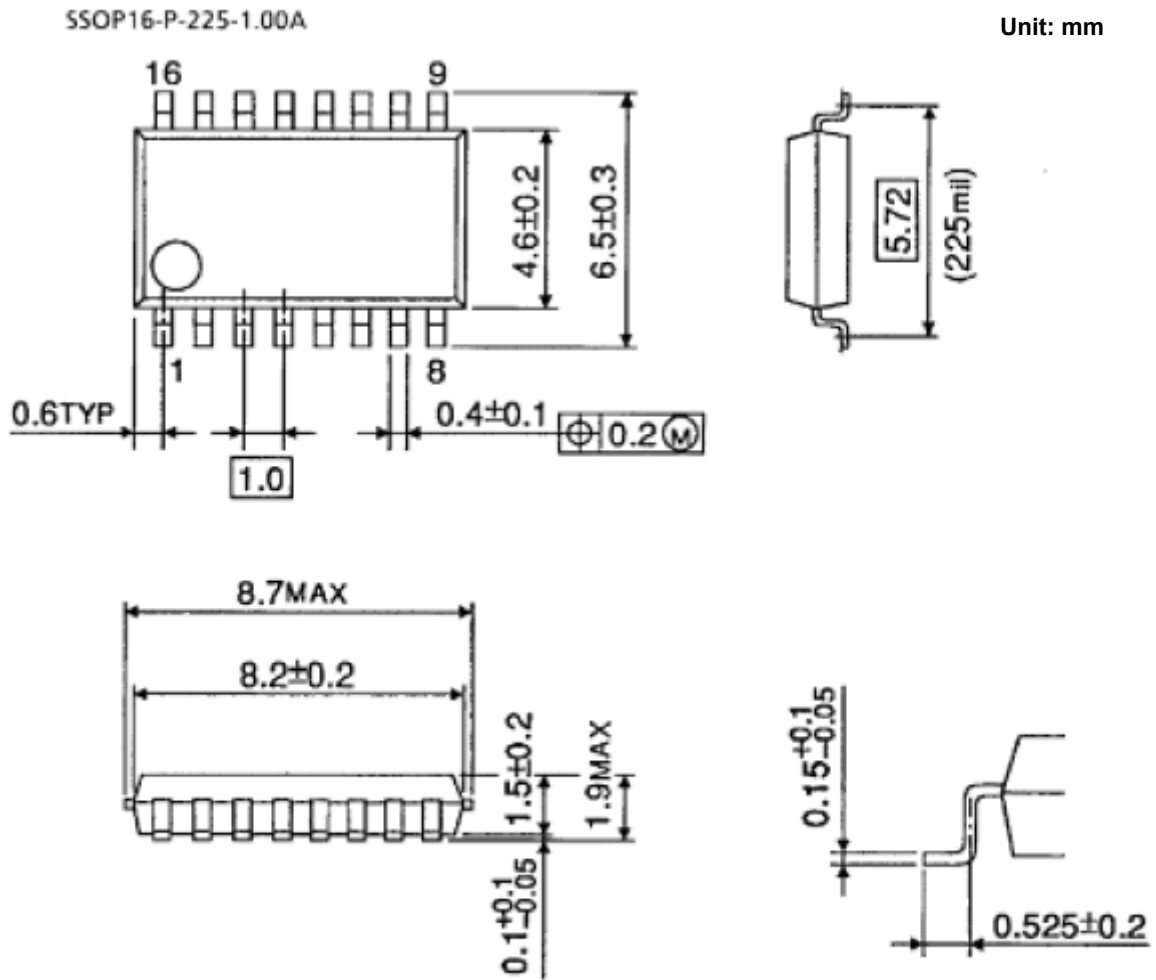

Weight: 0.14 g (Typ.)

Notes on Contents

1. Block Diagrams

Some of the functional blocks, circuits, or constants in the block diagram may be omitted or simplified for explanatory purposes.

2. Equivalent Circuits

The equivalent circuit diagrams may be simplified or some parts of them may be omitted for explanatory purposes.

3. Timing Charts

Timing charts may be simplified for explanatory purposes.

4. Application Circuits

The application circuits shown in this document are provided for reference purposes only. Thorough evaluation is required, especially at the mass production design stage.

Toshiba does not grant any license to any industrial property rights by providing these examples of application circuits.

5. Test Circuits

Components in the test circuits are used only to obtain and confirm the device characteristics. These components and circuits are not guaranteed to prevent malfunction or failure from occurring in the application equipment.

IC Usage Considerations

Notes on handling of ICs

- [1] The absolute maximum ratings of a semiconductor device are a set of ratings that must not be exceeded, even for a moment. Do not exceed any of these ratings.
Exceeding the rating(s) may cause the device breakdown, damage or deterioration, and may result injury by explosion or combustion.
- [2] Use an appropriate power supply fuse to ensure that a large current does not continuously flow in case of over current and/or IC failure. The IC will fully break down when used under conditions that exceed its absolute maximum ratings, when the wiring is routed improperly or when an abnormal pulse noise occurs from the wiring or load, causing a large current to continuously flow and the breakdown can lead smoke or ignition. To minimize the effects of the flow of a large current in case of breakdown, appropriate settings, such as fuse capacity, fusing time and insertion circuit location, are required.
- [3] If your design includes an inductive load such as a motor coil, incorporate a protection circuit into the design to prevent device malfunction or breakdown caused by the current resulting from the inrush current at power ON or the negative current resulting from the back electromotive force at power OFF. IC breakdown may cause injury, smoke or ignition.
Use a stable power supply with ICs with built-in protection functions. If the power supply is unstable, the protection function may not operate, causing IC breakdown. IC breakdown may cause injury, smoke or ignition.
- [4] Do not insert devices in the wrong orientation or incorrectly.
Make sure that the positive and negative terminals of power supplies are connected properly.
Otherwise, the current or power consumption may exceed the absolute maximum rating, and exceeding the rating(s) may cause the device breakdown, damage or deterioration, and may result injury by explosion or combustion.
In addition, do not use any device that is applied the current with inserting in the wrong orientation or incorrectly even just one time.

Points to remember on handling of ICs**(1) Heat Radiation Design**

In using an IC with large current flow such as power amp, regulator or driver, please design the device so that heat is appropriately radiated, not to exceed the specified junction temperature (T_j) at any time and condition. These ICs generate heat even during normal use. An inadequate IC heat radiation design can lead to decrease in IC life, deterioration of IC characteristics or IC breakdown. In addition, please design the device taking into consideration the effect of IC heat radiation with peripheral components.

(2) Back-EMF

When a motor rotates in the reverse direction, stops or slows down abruptly, a current flows back to the motor's power supply due to the effect of back-EMF. If the current sink capability of the power supply is small, the device's motor power supply and output terminals might be exposed to conditions beyond absolute maximum ratings. To avoid this problem, take the effect of back-EMF into consideration in system design.

RESTRICTIONS ON PRODUCT USE

- Toshiba Corporation, and its subsidiaries and affiliates (collectively "TOSHIBA"), reserve the right to make changes to the information in this document, and related hardware, software and systems (collectively "Product") without notice.
- This document and any information herein may not be reproduced without prior written permission from TOSHIBA. Even with TOSHIBA's written permission, reproduction is permissible only if reproduction is without alteration/omission.
- Though TOSHIBA works continually to improve Product's quality and reliability, Product can malfunction or fail. Customers are responsible for complying with safety standards and for providing adequate designs and safeguards for their hardware, software and systems which minimize risk and avoid situations in which a malfunction or failure of Product could cause loss of human life, bodily injury or damage to property, including data loss or corruption. Before customers use the Product, create designs including the Product, or incorporate the Product into their own applications, customers must also refer to and comply with (a) the latest versions of all relevant TOSHIBA information, including without limitation, this document, the specifications, the data sheets and application notes for Product and the precautions and conditions set forth in the "TOSHIBA Semiconductor Reliability Handbook" and (b) the instructions for the application with which the Product will be used with or for. Customers are solely responsible for all aspects of their own product design or applications, including but not limited to (a) determining the appropriateness of the use of this Product in such design or applications; (b) evaluating and determining the applicability of any information contained in this document, or in charts, diagrams, programs, algorithms, sample application circuits, or any other referenced documents; and (c) validating all operating parameters for such designs and applications. **TOSHIBA ASSUMES NO LIABILITY FOR CUSTOMERS' PRODUCT DESIGN OR APPLICATIONS.**
- Product is intended for use in general electronics applications (e.g., computers, personal equipment, office equipment, measuring equipment, industrial robots and home electronics appliances) or for specific applications as expressly stated in this document. Product is neither intended nor warranted for use in equipment or systems that require extraordinarily high levels of quality and/or reliability and/or a malfunction or failure of which may cause loss of human life, bodily injury, serious property damage or serious public impact ("Unintended Use"). Unintended Use includes, without limitation, equipment used in nuclear facilities, equipment used in the aerospace industry, medical equipment, equipment used for automobiles, trains, ships and other transportation, traffic signaling equipment, equipment used to control combustions or explosions, safety devices, elevators and escalators, devices related to electric power, and equipment used in finance-related fields. Do not use Product for Unintended Use unless specifically permitted in this document.
- Do not disassemble, analyze, reverse-engineer, alter, modify, translate or copy Product, whether in whole or in part.
- Product shall not be used for or incorporated into any products or systems whose manufacture, use, or sale is prohibited under any applicable laws or regulations.
- The information contained herein is presented only as guidance for Product use. No responsibility is assumed by TOSHIBA for any infringement of patents or any other intellectual property rights of third parties that may result from the use of Product. No license to any intellectual property right is granted by this document, whether express or implied, by estoppel or otherwise.
- **ABSENT A WRITTEN SIGNED AGREEMENT, EXCEPT AS PROVIDED IN THE RELEVANT TERMS AND CONDITIONS OF SALE FOR PRODUCT, AND TO THE MAXIMUM EXTENT ALLOWABLE BY LAW, TOSHIBA (1) ASSUMES NO LIABILITY WHATSOEVER, INCLUDING WITHOUT LIMITATION, INDIRECT, CONSEQUENTIAL, SPECIAL, OR INCIDENTAL DAMAGES OR LOSS, INCLUDING WITHOUT LIMITATION, LOSS OF PROFITS, LOSS OF OPPORTUNITIES, BUSINESS INTERRUPTION AND LOSS OF DATA, AND (2) DISCLAIMS ANY AND ALL EXPRESS OR IMPLIED WARRANTIES AND CONDITIONS RELATED TO SALE, USE OF PRODUCT, OR INFORMATION, INCLUDING WARRANTIES OR CONDITIONS OF MERCHANTABILITY, FITNESS FOR A PARTICULAR PURPOSE, ACCURACY OF INFORMATION, OR NONINFRINGEMENT.**
- Do not use or otherwise make available Product or related software or technology for any military purposes, including without limitation, for the design, development, use, stockpiling or manufacturing of nuclear, chemical, or biological weapons or missile technology products (mass destruction weapons). Product and related software and technology may be controlled under the Japanese Foreign Exchange and Foreign Trade Law and the U.S. Export Administration Regulations. Export and re-export of Product or related software or technology are strictly prohibited except in compliance with all applicable export laws and regulations.
- Please contact your TOSHIBA sales representative for details as to environmental matters such as the RoHS compatibility of Product. Please use Product in compliance with all applicable laws and regulations that regulate the inclusion or use of controlled substances, including without limitation, the EU RoHS Directive. TOSHIBA assumes no liability for damages or losses occurring as a result of noncompliance with applicable laws and regulations.